



UNITED BRASS WORKS, INC.
 714 S. Main St., Randleman, NC 27317
 Tel: 800-334-3035 Fax: 800-498-4696 www.ubw.com



Model 90WBD Wafer Check Valve

UL US **UL Listed • FM Approved***

**As antiwater hammer check valve for fire pump service only!*

250 WOG @ 180 ° Max
100% Pressure Tested

*Approved by New York City Board of Standards & Appeals
 under Calendar No. 157-84-SA.*

MATERIAL LIST

NO.	DESCRIPTION	MATERIAL
1	Body	Ductile Iron
2	Seat Ring Assembly	Bronze
3	Screw	Stainless Steel
4	Seat Ring O-Ring	Buna-N
5	Face O-Ring	Buna-N
6	Street Elbow	Galvanized Steel
7	Ball Drip	(See spec for 235 1/2")

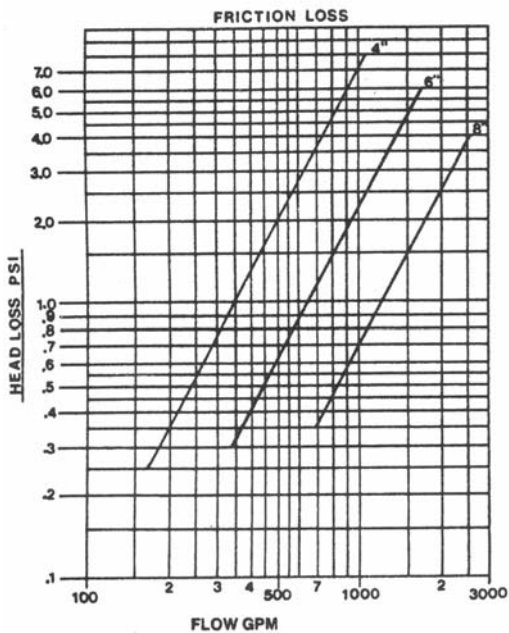
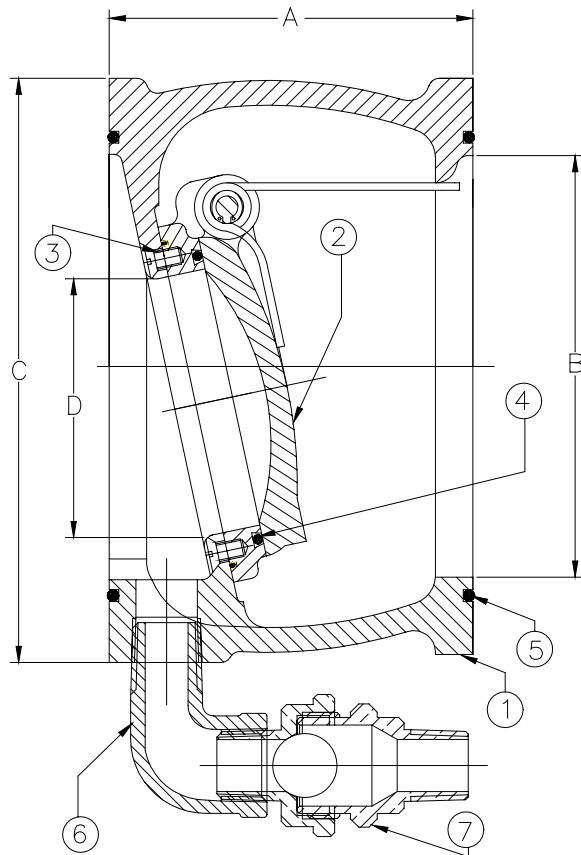

Size	A	B	C	D	Ship Wt. (lbs)	Qty. Per Ctn.
4"	4.25	4.03	6.86	3.00	15.0	1