

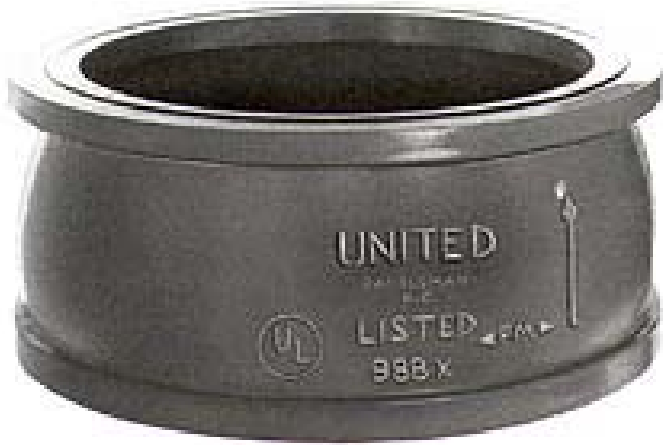

UNITED BRASS WORKS, INC.

714 S. Main St., Randleman, NC 27317

Tel: 800-334-3035 Fax: 800-498-4696 www.ubw.com



Model 90 Wafer Check Valve



UL Listed • FM Approved*

*As antiwater hammer check valve for fire pump service only!

250 WOG @ 180° Max

100% Pressure Tested

Approved by New York City Board of Standards & Appeals under Calendar No. 157-84-SA.

The 4" size is provided with 1/2" pipe plug in drain port as standard configuration.

MATERIAL LIST

NO.	DESCRIPTION	MATERIAL
1	Body	Ductile Iron
2	Seat Ring Assembly	Bronze
3	Screw	Stainless Steel
4	Seat Ring O-Ring	Buna-N
5	Face O-Ring	Buna-N
6	Pipe Plug	Steel

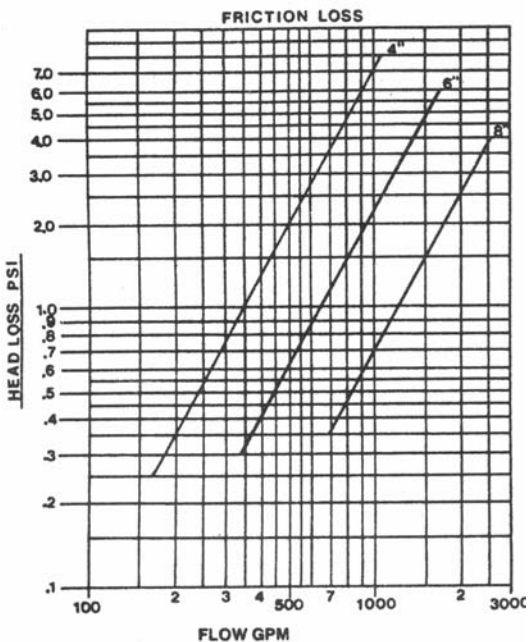
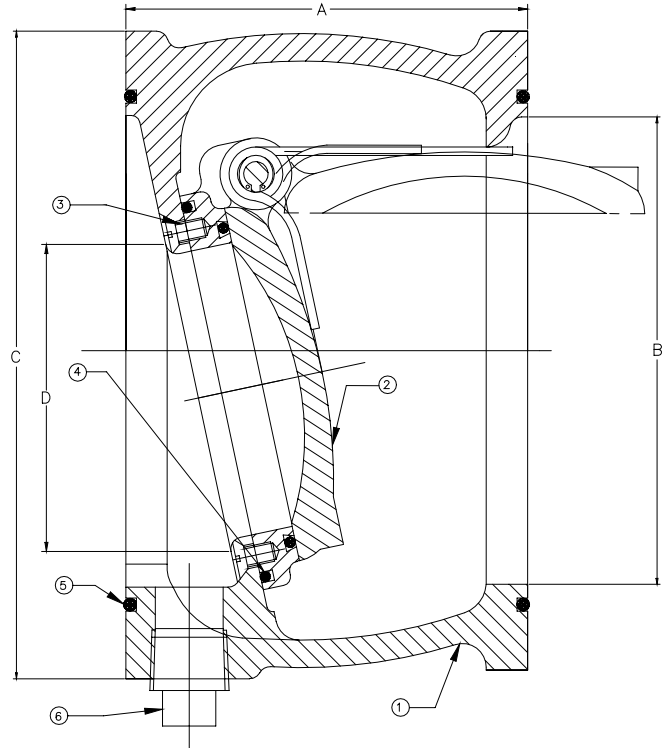

Size	A	B	C	D	Ship Wt. (lbs)	Qty. Per Ctn.
4"	4.25	4.03	6.86	3.00	15.0	1
6"	3.75	6.06	8.50	4.50	19.0	1
8"	3.75	7.98	11.00	6.00	29.0	1