



UNITED BRASS WORKS, INC.

714 S. Main St., Randleman, NC 27317

Tel: 800-334-3035 Fax: 800-498-4696 www.ubw.com



Model 76 Gauge Test Valve

300 WOG @ 180 ° Max
100% Pressure Tested
Screwed Ends

MATERIAL LIST

NO.	DESCRIPTION	MATERIAL
1	Screw	Stainless Steel
2	Hand Wheel	Aluminum
3	Packing Nut	Brass
4	O-Ring	Nitrile
5	Washer	Brass
6	Stem	Brass
7	Body	Bronze

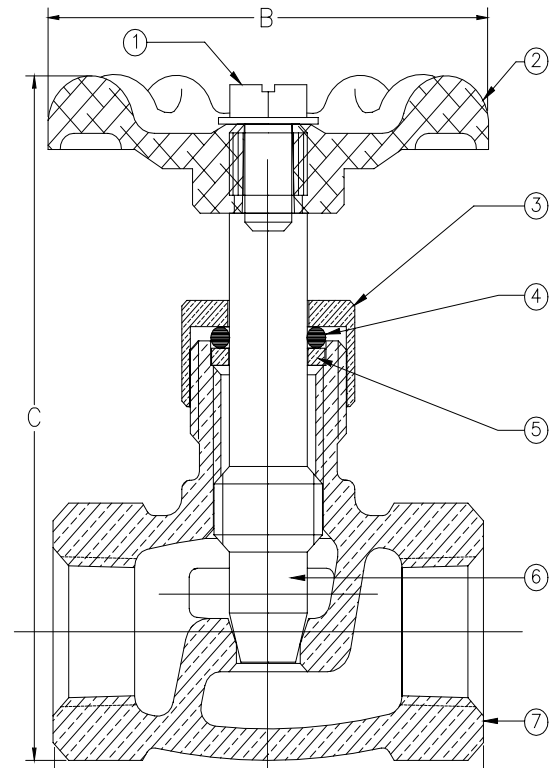

Size	1/4"
A	1.750
B	1.734
C	2.469
Ship Wgt. (lbs.)	0.34
Qty. Per Ctn.	25