



UNITED BRASS WORKS, INC.

714 S. Main St., Randleman, NC 27317

Tel: 800-334-3035 Fax: 800-498-4696 www.ubw.com



Model 68 Threaded Check Valve

Male NPT x Female NPT

UL *UL Listed • FM Approved*

**As antiwater hammer check valve for fire pump service only!*

250 WOG @ 180 ° Max

100% Pressure Tested

Threaded Ends

MATERIAL LIST

NO.	DESCRIPTION	MATERIAL
1	Body	Ductile Iron
2	Seat Ring Assembly	Bronze
3	Seat Ring Gasket	Buna
4	Pipe Plug	Steel
5	Screw	Stainless Steel

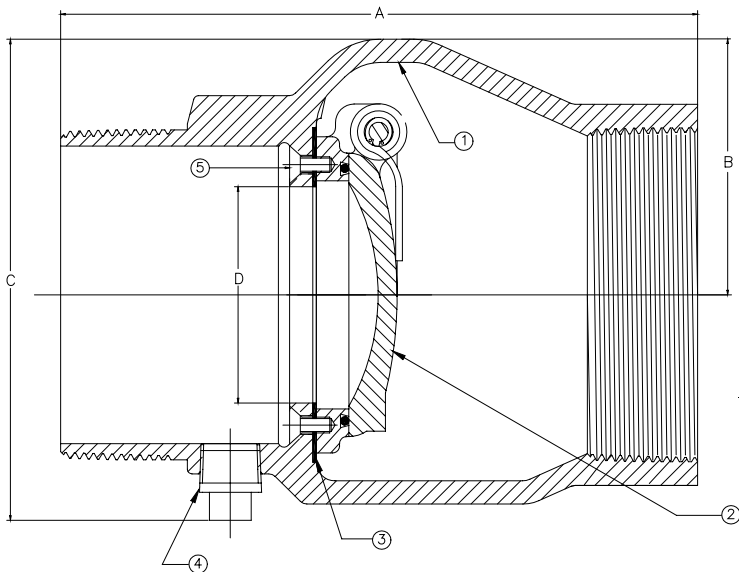
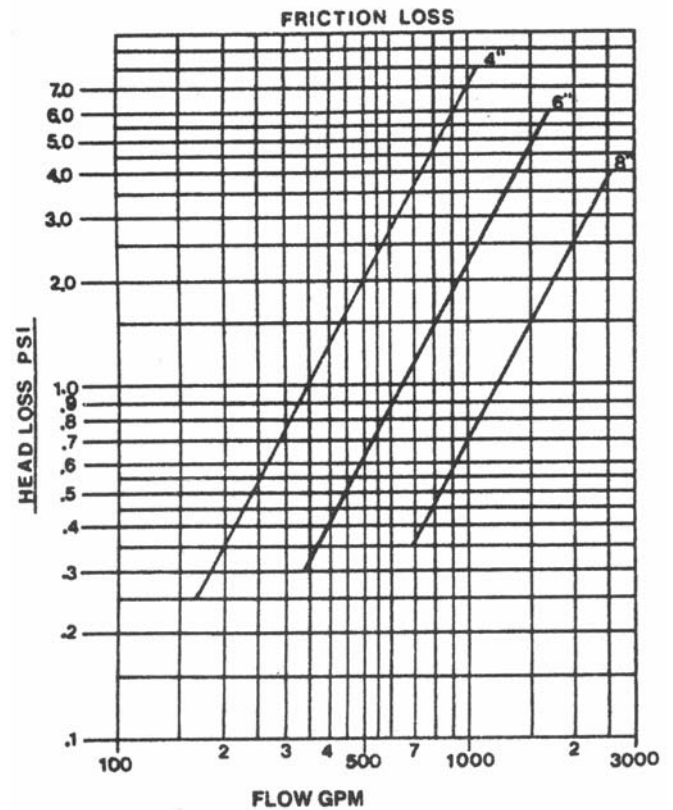

Size	A	B	C	D
4"	8.56	3.44	6.25	3.00

Ship Wgt. (lbs.)	Qty. Per Ctn.
17.0	1