



UNITED BRASS WORKS, INC.

714 S. Main St., Randleman, NC 27317

Tel: 800-334-3035 Fax: 800-498-4696 www.ubw.com



Model 67 Grooved Check Valve



UL US UL Listed • FM Approved*

**As antiwater hammer check valve for fire pump service only!*

250 WOG @ 180 ° Max

100% Pressure Tested

Grooved Ends

*4" size standard drilled, tapped
and fitted with 1/2" drain plug.*

(Will also allow installation of UBW #235 Ball Drip Valve)

MATERIAL LIST

NO.	DESCRIPTION	MATERIAL
1	Body	Ductile Iron
2	Seat Ring Assembly	Bronze
3	Seat Ring Gasket	Buna
4	Pipe Plug	Steel
5	Screw	Stainless Steel

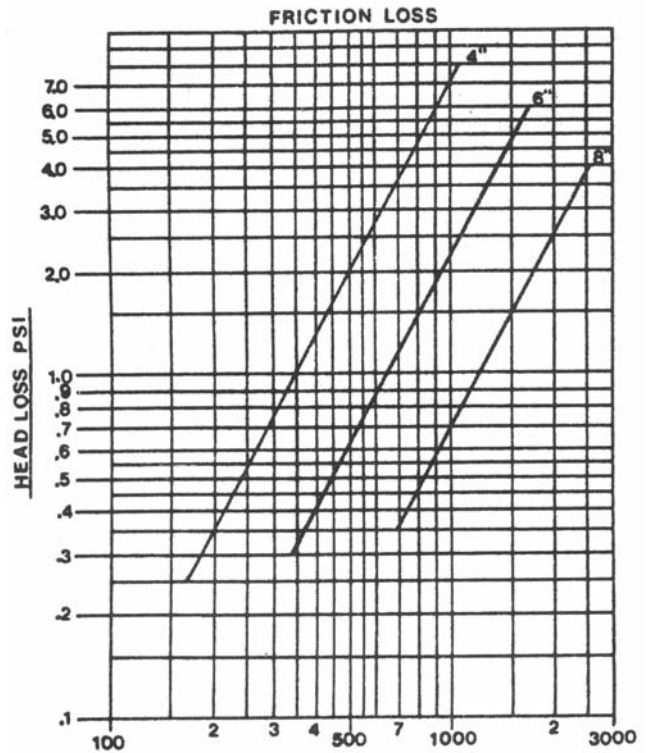
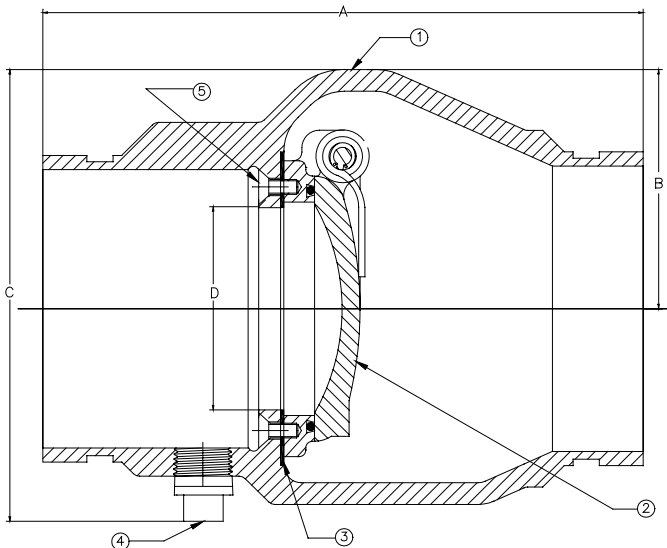

Size	A	B	C	D
4"	8.56	3.44	6.25	3.00

Shit Wgt. (lbs.)	Qty. Per Ctn.
17.0	1