



UNITED BRASS WORKS, INC.

714 S. Main St., Randleman, NC 27317

Tel: 800-334-3035 Fax: 800-498-4696 www.ubw.com



Model 210S Swing Check Valve



200 WOG @ 180° Max
100% Pressure Tested • Integral Seat
Threaded Ends • Metal Disc

Swing Check valve Special with 1/32" Hole in Clapper for use in Anti-Freeze Loop NFPA 13 5-5.4.

Not Recommended for Pulsating or Vibrating Service!
Install in horizontal position only!

MATERIAL LIST		
NO.	DESCRIPTION	MATERIAL
1	Cap (1/4" - 1") Cap (1/4" - 2")	Bronze Brass
2	Washer	Brass
3	Body	Bronze
4	Disc	Brass
5	Hinge	Stainless Steel

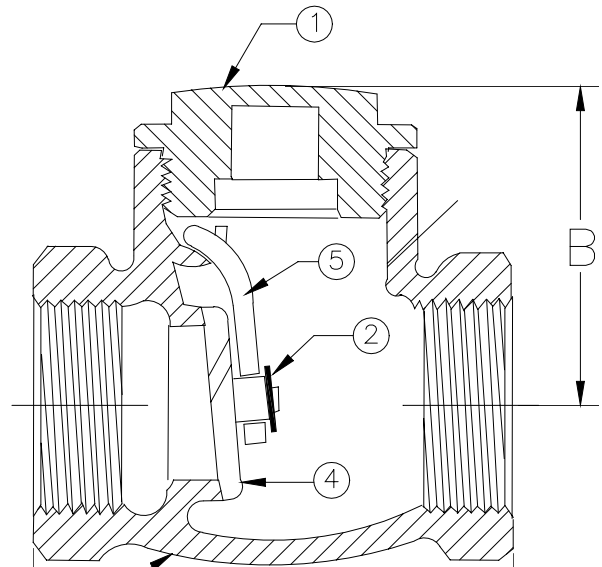

Size	1/4"	3/8"	1/2"	3/4"	1"	1 1/4"	1 1/2"	2"
A	1.89	1.89	2.14	2.51	3.03	3.45	3.81	4.44
B	1.22	1.22	1.28	1.53	2.06	2.20	2.20	2.86
Ship Wgt. (lbs.)	0.45	0.45	0.58	0.81	1.62	1.81	2.41	3.42
Qty. Unit Pack	12	12	12	12	6	6	4	2
Qty. Per Case	60	60	60	60	30	18	12	6